

# AUTO FOCUS ZOOM CAMERA

## DAZ-537

**37X Zoom, TDN, 600TVL  
0.00004Lux, DNR, WDR**

### Features

- 1/4" Color Sony Super HAD CCD
- High resolution:600TVL, 37X Optical Zoom & 16X Digital Zoom
- Removed noise & Ghost images with DNR
- Day & Night with ICR (Infrared Cut filter Removable)
- Privacy(8 Zones), Motion Detection

### Picture



### Dimension

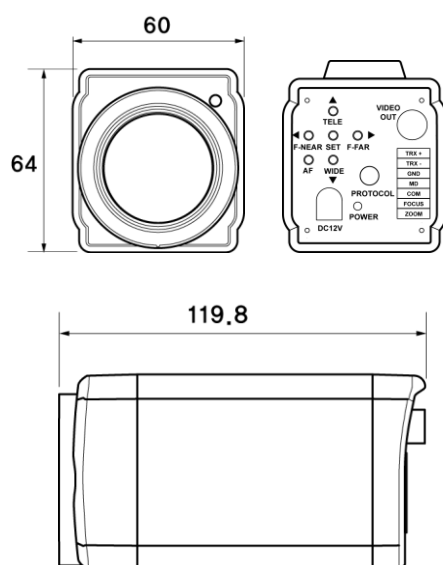

unit : mm

### Specifications

MODEL	DAZ-537	
Signal system	NTSC	PAL
Image sensor	1/4" Sony Super HAD CCD	
Total pixels	811(H)X508(V)	795(H)X596(V)
Effective pixels	768(H)X494(V)	752(H)X582(V)
Resolution	Color : 600TVL(Min), B/W : 700TVL(Min)	
Scanning frequency	15.734KHz(H), 60(V)	15.625KHz(H), 50(V)
Scanning system	2:1 Interlace 525 Lines/60Fields/30Frames	2:1 Interlace 625 Lines/50Fields/25Frames
Shutter speed	1/60~1/120,000 sec	1/50~1/120,000 sec
Minimum illumination	0.5Lux @F1.6 (Normal Color Mode) 0.1Lux @F1.6 (B/W Mode) 0.00004Lux @F1.6 (Sense-up 512X)	
Zoom rate	37X, f=3.5~129.5mm (F1.6~3.9)	
Min. Focus distance	1m	
Angle of view	H: 55.5°(Wide)~1.59°(Tele), V:42.5°(Wide)~1.19°(Tele)	
Back light	BLC / HLC	
Day & Night	Auto / Color / B/W	
Privacy zones masking	On (8 Zones) / Off	
AGC	Low / Middle / High / Off	
Camera ID	On ( 255 ID Selectable ) / Off	
White balance	ATW / Outdoor / AWC / Manual	
SSNR	Low / Middle / High / Off	
OSD	Built-in	
DIS	On / Off	
Communication	RS-485, Multi Protocol (Pelco D,P, D-max)	
S/N ratio	More than 50dB	
Video output	Composite video output 75Ω terminated	
Sync. system	Internal	
Operating humidity	30 % ~ 90 % RH	
Operating temperature	- 10°C to 50°C	
Dimension	60(W) X 64(H) X 119.8(D)mm	
Weight	About 400g	
Power consumption	Max 5W	
Power supply	DC 12V (±10%) 500mA	