

COLOR BOX CAMERA

DCC-500F

**600TVL, 3DNR
True Day & Night, D-WDR**

Features

- 410K Pixel Sony 1/3" CCD
- High Resolution of 600 TV Lines
- Low up to 0.00001 Lux. True Day & Night (ICR)
- Digital WDR, Privacy Masking Zone, Motion Detection Function
- 3D-DNR (Digital Noise Reduction), Digital Zoom (32x), White Defect Restoration
- Built-in OSD (On Screen Display) Menu, Multi Language support
- C/CS Mount Lens

Picture



Dimensions

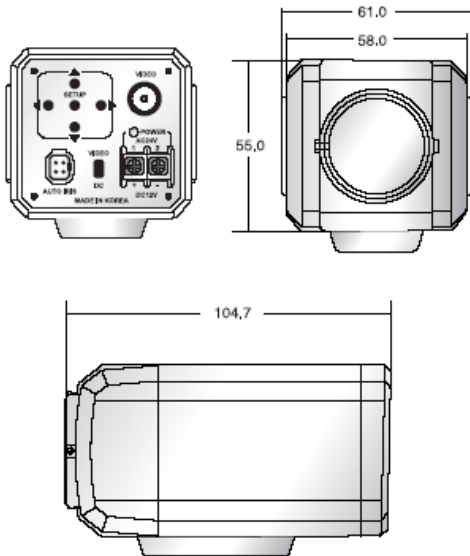

unit : mm

Specifications

MODEL	DCC-500F (DN)	
Signal system	NTSC	PAL
Image Sensor	1/3" Sony Super HAD CCD	
Total Pixels	811(H)X508(V)	795(H)X596(V)
Effective Pixels	768(H)X494(V)	752(H)X582(V)
Resolution	Color : 600 TV Lines (B/W 700 TV Lines with ICR)	
Scanning Frequency	15.734KHz(H), 60(V)	15.625KHz(H), 50(V)
Shutter Speed	1/60~1/120,000 sec/ FLK	1/50~1/100,000 sec/ FLK
Min. Illumination	Color : 0.1 Lux@F1.2 0.00001Lux (Sense-up 256x)	
Day & Night	Color / Auto / EXT / B/W	
Digital WDR	On / Off	
White Balance	ATW / AWB / AWC-Set / Manual / Indoor / Outdoor	
BLC	BLC / HSBLC	
AGC	Low / Middle / High / Off	
3D-DNR	On / Off	
Privacy Zone	8 Programmable Zones	
Motion Detection	4 Programmable Zones	
Sharpness	Level : 0 ~ 31	
Camera Title	On / Off	
S/N Ratio	More than 50dB	
Video Output	Composite video output 75 ohm terminated	
Lens Mount	C / CS Mount	
Sync. System	Internal	
Operating Humidity	30 % ~ 90 % RH	
Operating Temp.	- 10°C to 50°	
Dimension	61(W) X 55(H) X 104.7(D)mm	
Weight	About 420g	
Power Consumption	Max 3W	
Power Supply	DC 12 V(10.2V~14.5 V) Dual Voltage(Optional) : AC24V / DC12V	